



Portola Packaging Ltd Product Specification

38mm 3-Lead Cap



PRODUCT DESCRIPTION

Portola's 38mm 3 lead closure has been designed for a 38mm 3-Start Neck finish. The primary seal is created by a bore seal valve. The primary seal is designed to vent excessive gas generated by non-carbonated fermenting beverages. Tamper Evidence is provided by a drop down retained ring which detached from the closure upon initial opening. It is suitable for PET & HDPE containers, cold fill operation and the J Band Design allows for greater 'A' ring variation. The J Band design also leads to reduced application forces. This product is suitable for Aseptic Rinsing. This Product is available with an Oxygen Scavenging additive.
Product Code: 311

DIMENSIONS

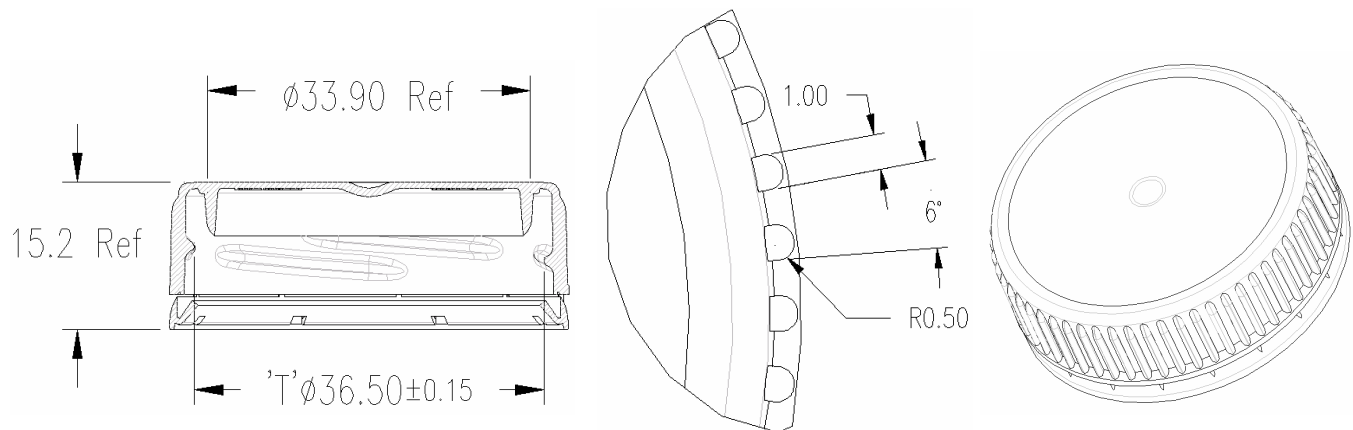

PACKING METHOD

- Approx 1000 caps per bag, 2 bags per box..
- 25 boxes per pallet.
- 50,000 caps per pallet.
- Carton Identification - each filled carton will display the following, name of manufacturer, date of manufacture, mould identification, product name and colour, average quantity and box number.
- Corrugated carton - Board grade 186T2/175SC/190T3
- Pallet Identification - part number, pallet number, date, quantity

PALLET DETAILS

- Width 1000 mm
 - Length 1200 mm
 - Height 1600 mm
- } Including Pallet

MATERIALS

All raw materials used in the process including additives and masterbatches are fully approved for direct food contact and meet the requirement of all relevant EU directives and the FDA (Food and Drug Administration).

RECOMMENDED STORAGE CONDITIONS

- In a dry dust free environment..
- Product should not be stored where it is subject to water damage or exposure to chemicals or odour.
- Keep the cartons closed and taped and bags knotted at all times until immediately prior to use, if less than a full carton is to be used, the bag containing the remaining closures should be retied and the top flaps of the carton secured to prevent contamination.
- Product should be stored in temperatures between 10°C and 30°C for 24 hours prior to use.
- Maximum storage temperature prior to application 6 months 5-30°C
- Minimum storage temperature after application 3°C
- Maximum storage temperature after application 25°C
- Maximum palletized limit; 2 high with layer pad.
- Product to be stored in low UV conditions out of direct sunlight.
- Maximum recommended time on container, 12 months.

SUITABILITY TESTING

Taint and Odour - to test for tainting of the water

ASTHETICS

- Colours - Available in wide variety of Portola standard colours Blue, Red, and Green.
- Custom colours also available based on volume.

HANDLING

- If fed to hopper/sorter to be via belt convey or with flights used ensure there are no trap points as to cause damage.
- Sorter to ensure smooth feed with no trap points to cause jam-ups or damage to closures. Sorter should be able to sort the caps at both extremes of height allowance. This is a minimum of 14.9 mm and maximum of 15.5 mm.
- Chute to be constructed to ensure closures feed freely without being able to jam or piggy - back.
- Application of cap should be consistent in feed and height position of cap. The use of a pre spin finger and ski plate to engage threads is recommended to ensure the cap is not dislodged as the bottle is transferred to the capping turret pedestals.
- Capping chucks should be set to apply caps between 16-18lbf (1.8-2.0 Nm) with a recommended minimum of 3.5 full rotations.
- The jaws of the Chucks must be set to fully grip the cap to be able to transmit this torque without slipping on the finger grip of cap.
- Bottle change parts should be able to control bottles to resist turning as torque is applied.
- Venting spec; 1.5 bar max, 1 bar min, reseal @ 0.5 bar
- **CAUTION:** These Closures are Torque Tested & ESR Tested under Laboratory conditions up to 22lbf (2.5Nm), It is not recommended that on torques in excess of 20lbf are used with this product to allow for a safety factor.

IMPORTANT NOTE

While the supplier (Portola Packaging) take every precaution and use both their experience and that of their suppliers in the selection of materials and processing of the product, it is deemed ultimately the responsibility of the client to confirm and maintain tests which assure compatibility with the product and mating items. In respect of but not limited to integrity of product, security of package, taint and smell.

It is the customers responsibility to ensure local regulations are met, as the supplier has no way of knowing the areas or countries the product will be sold or marketed in.

The supplier's responsibility shall be restricted to notification of proposed changes in conditions or materials, which may require secondary testing and customer approval.