



Portola Packaging Ltd UK Product Specification

5 Gallon Non-Spill Closure



PRODUCT DESCRIPTION

The 5 Gallon Non-Spill Cap is a liquid proof Snap-On tamper evident closure designed to provide suitable sealing for use in conjunction with liquid product which are both inert and none carbonated in nature. When applied under the correct conditions the tamper evidence is provided to the base caps by means of a visible tear line and to the non spill plug void by means of a single stick label, when removed this allows the closure to be installed to most water cooler assemblies creating a non-spill design.

DIMENSIONS

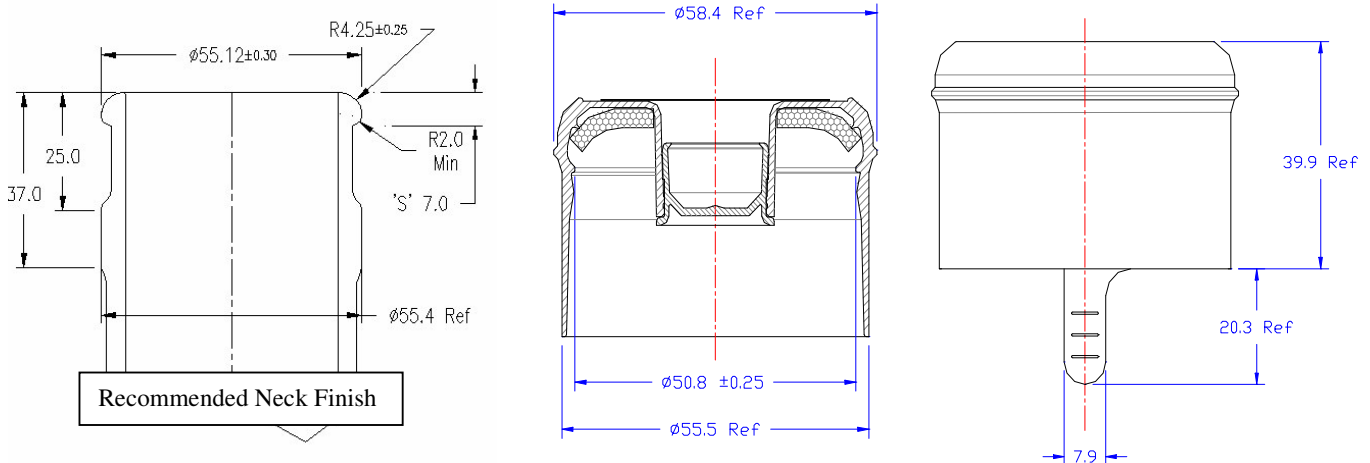

PACKING METHOD

- Approx 500 caps per box, double bagged
- 30 boxes per pallet.
- 15,000 caps per pallet.
- Carton Identification - each filled carton will display the following, name of manufacturer, date of manufacture, product name and colour, average quantity and box number.
- Corrugated carton - Board grade 186T2/175SC/190T
- Pallet Identification - part number, pallet number, date, Qty

PALLET DETAILS

- Width 1000mm
 - Length 1200mm
 - Height 2300mm
- Including Pallet

MATERIALS

All raw materials used in the process including additives and masterbatches are fully approved for direct food contact and meet the requirement of all relevant EU directives and the FDA (Food and Drug Administration).
This applies to the Cap, Plug, and Foam, but not the Label.

RECOMMENDED STORAGE CONDITIONS

- In a dry dust free environment.
- Production shall be rotated on a “first in first out” basis. The product should be used (applied to bottle) within 9 months from the date of manufacture and a further 6 months post application to the bottle/product.
- Product should not be stored where it is subject to water damage or exposure to chemicals or odour.
- Keep the cartons closed and taped and bags knotted at all times until immediately prior to use, if less than a full carton is to be used, the bag containing the remaining closures should be retied and the top flaps of the carton secured to prevent contamination.
- Caps are not to be stacked to cause damage to Packaging or Product within.
- Store within temperatures not below 5°C and not above 30°C.
- It is further recommended that the caps are stored in temperatures between 10°C and 30°C 24 hour’s prior to use.
- Caps must not be stored for a prolonged period in an ozonated environment.

SUITABILITY TESTING

- Taint and Odour - to test for tainting of the water under certain conditions.

ASTHETICS

- Labels - Logo/Print to suit customer requirements.
- Colours - Available in wide variety of Portola standard colours Blue, Dark Blue, Red, and Green. Custom colours also available based on volume.

HANDLING

- If fed to hopper/sorter to be via belt convey or with flights used ensure there are no trap points as to cause damage or removal of labels.
- Sorter to ensure smooth feed with no trap points to cause jam-ups or damage to closures.
- Chute to be constructed to ensure closures feed freely without being able to jam.
- Application top load force required 500 Newton’s.

IMPORTANT NOTE

While the supplier (Portola Packaging) take every precaution and use both their experience and that of their suppliers in the selection of materials and processing of the product, it is deemed ultimately the responsibility of the client to confirm and maintain tests which assure compatibility with the product and mating items. In respect of but not limited to integrity of product, security of package, taint and smell.

It is the customer’s responsibility to ensure local regulations are met, as the supplier has no way of knowing the areas or countries the product will be sold or marketed in.

The supplier’s responsibility shall be restricted to notification of proposed changes in conditions or materials, which may require secondary testing and customer approval.