



Portola Packaging Ltd UK Product Specification

28mm 1881 NXT Push Pull Sports Closure



PRODUCT DESCRIPTION

The 28mm NXT Push Pull Sports Closure, commonly referred to as the 1881 NXT cap, is to be used in conjunction with liquid product which is both inert and none carbonated in nature. The NXT is a tamper evident closure when applied under the correct conditions, with a tamper evident Spout and removeable Dust Cover. It is a screw-on cap capable of high speed application and designed to be compatible with PET containers that have a 28mm industry standard 1881 Neck Finish (ref PCO-1881) . This closure complies with the BSDA code of practice for Sports Closures.

WARNING: CHOKING HAZARD – Cap not suitable for children less than 36 months, as it contains small parts, this product must carry a clear warning label.

DIMENSIONS

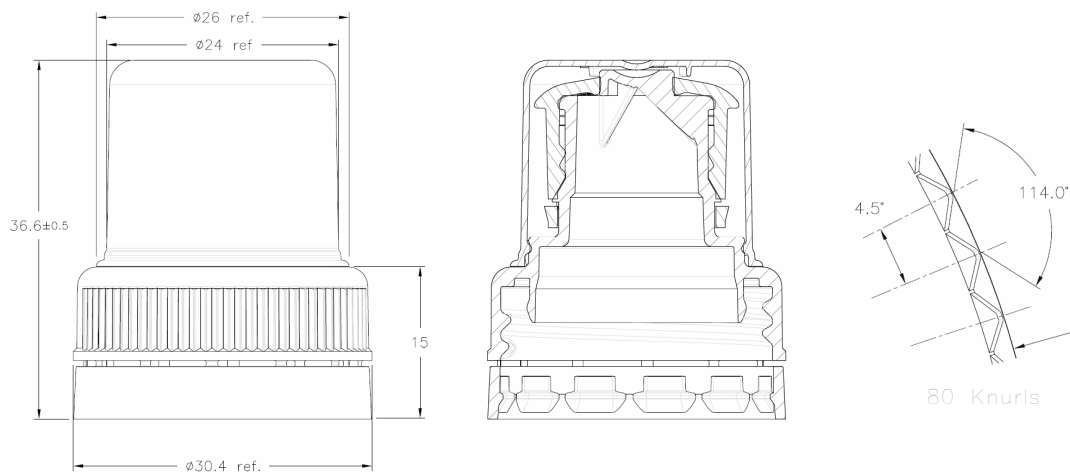

PACKING METHOD

- Approx. 1850 caps per bag. 1 bag per box (Box Quantity may increase with packaging trials)
- 25 boxes per pallet. 46,250 caps per pallet. (Total Quantity may increase with packaging trials)
- Corrugated carton – Board grade / 186T2 / 175SC / 190T3
- Carton Identification – Each filled carton will display the name of manufacturer, date of manufacture, product identification code and name, base and spout colour, average Qty. and box number.
- Pallet Identification – Date, product identification code and name, Pallet number, Qty.

PALLET DETAILS

- | | |
|--|---------------------------------------|
| <ul style="list-style-type: none"> • Width 1000mm • Length 1200mm • Height 1600mm • Weight 229Kg | } Including
Pallet
(weight TBC) |
|--|---------------------------------------|

MATERIALS

All materials used in the process including additives and masterbatches are fully approved for direct food contact and meet the requirements of all relevant EU directives and the FDA (Food and Drug Administration). This applies to the Base cap, Spout and Dust cover.

RECOMMENDED STORAGE CONDITIONS

- In a dry, dust free environment.
- Production shall be rotated on a “first in first out” basis. The product should be used within 6 months of the date of manufacture and. The post application shelf life is 6 months.
- Product should not be stored where it is subject to water damage or exposure to chemicals or odour.
- Keep the Cartons closed and bags knotted at all times until immediately prior to use.
- Avoid double stacking which will cause damage to Packaging or Product within.
- Recommend that Cartons be stacked one pallet high only.
- Avoid temperature extremities keep away from temperatures below 5°C and above 30°C.
- It is further recommended that the caps are stored in temperatures between 10°C and 30°C 24 hours prior to use.

SUITABILITY TESTING

- Taint and Odour - to test for tainting of filled product and taste of closure in mouth under certain conditions, it is highly recommended for the client to also carry out such tests at appropriate timings to ensure ongoing compatibilities with ingredients, preservative and cleaning agents.

ASTHETICS

- Colours – Base cap available in wide variety of Portola standard colours: -
 - Midnight Blue
 - Orange
 - Lavender
 - Green
 - Red
 - Yellow
 - Black
- Dust cover – Natural
- Spout – White

Custom colours also available based on volumes.

HANDLING / APPLICATION

- Feed, if via hopper and belt conveyor with flights, must ensure no trap points so as to cause damage or disassembly of closure.
- Sorter to be set to ensure smooth feed with no trap points to cause jam-ups or damage to or disassembly of closures.
- Chute constructed to ensure closures feed freely without being able to jam. Recommend that sorter feed is shut off when chute full to prevent unnecessary force or damage to caps.
- Chucks must be constructed to match both: -
 1. Knurl pitch – so no swarfing / slip on application.
 2. Depth and profile of closure to include Dust cover.
- Dust cover must fit chuck profile to prevent damage / sticking in chuck or allow too much movement so allowing cap to ‘rock’ and apply ‘cocked’
- Chuck depth, either jaw type or solid construction, must not interfere with Tamper band of base cap. T/E band must be able to expand on application to bottle neck to prevent ‘bridge’ breakage.
- Torque range; Application between 12–18in/lb, provides Removal Torque 7-15in/lb.
- We recommend the proper chuck turn ratio Vs Cam drop to ensure correct application.

IMPORTANT NOTE

- While the supplier, (Portola Packaging) take every precaution and use both their experience and that of their suppliers in the selection of materials and processing of the product, it is deemed ultimately the responsibility of the client to confirm and maintain tests, which assure compatibility with the product and mating items in respect of but not limited to integrity of product, security of package, taint and smell.
- It is the customer’s responsibility to ensure local regulations are met, as the supplier has no way of knowing the areas or countries the product will be sold or marketed in.
- The supplier’s responsibility shall be restricted to notification of proposed changes in conditions or materials, which may require secondary testing and customer approval.
- Please consider Top Load limitations when stacking finished (filled) product, this should be tested and evaluated by site, and confirmed by transportation tests.